



## 12 Victoria Avenue Medindie SA

4  2  2 

Beautifully presented accomodating a flexible floor plan with formal dining and sitting rooms plus open plan kitchen/meals overlooking the outdoor entertaining area and sparkling swimming pool.

Comprising a further four spacious bedrooms, the master with walk-in robe and ensuite plus direct access to your own private courtyard. Offering ornate features throughout including picture rails, timber fireplaces and leadlight detailing.

Sited on a 650sqm approx. allotment, this residence is perfectly positioned close to Wilderness School, St Peters College, excellent primary schools, the Parklands, Adelaide Oval, cosmopolitan North Adelaide and the CBD.

**Price** : \$ 1,205,000  
**Building Size** : 167 sqm  
**Land Size** : 650 sqm  
**View** : <https://www.foxrealestate.com.au/property/12-victoria-avenue-medindie-sa/5731898>



**Andrew Fox**  
08 8267 4995

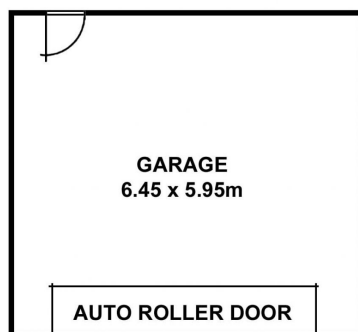
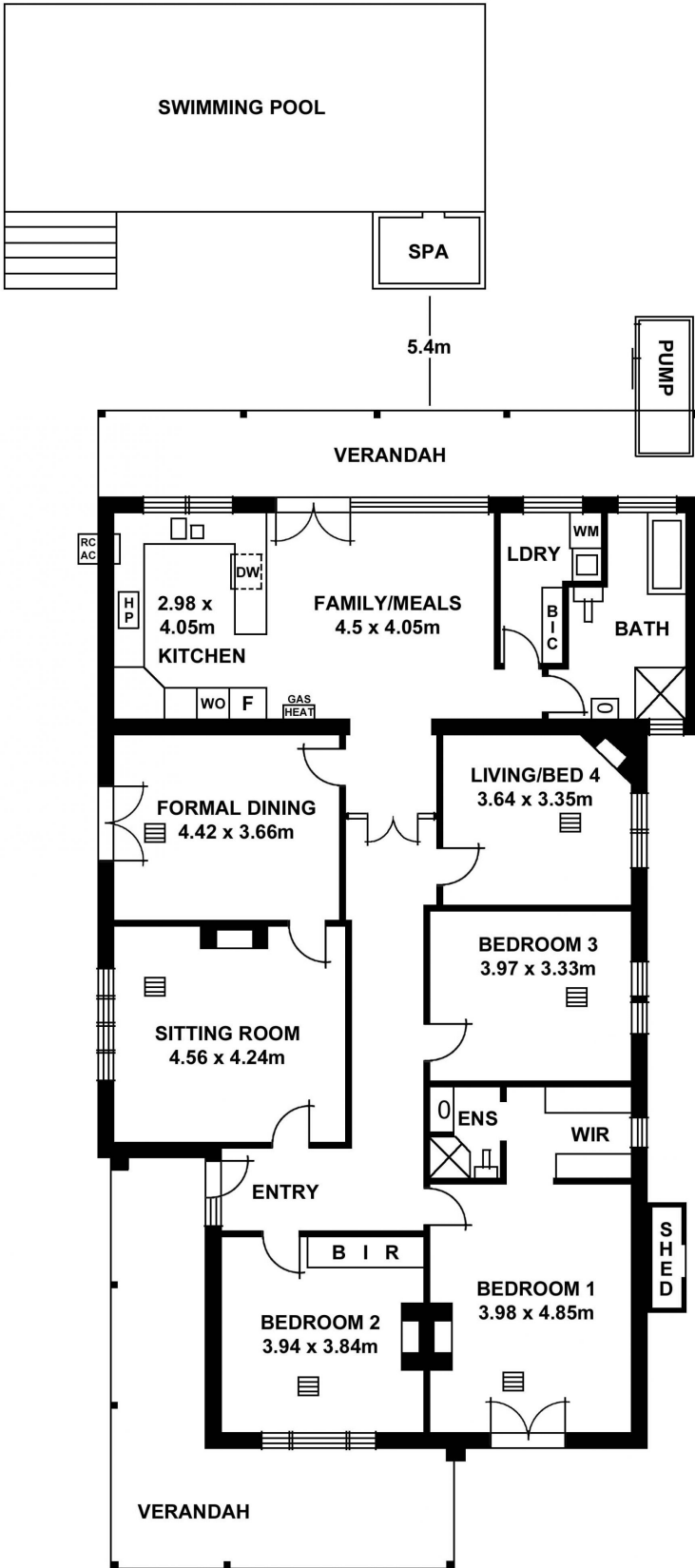

Living Area	194.45
Garage	40.32
Total approx	234.77sqm